



## Original Research Paper

## Attrition of methanol to olefins catalyst with high-velocity air jets at elevated temperature

Jingai Hao<sup>a,b</sup>, Yinfeng Zhao<sup>a</sup>, Mao Ye<sup>a,\*</sup>, Zhongmin Liu<sup>a</sup><sup>a</sup> National Engineering Laboratory for MTO, Dalian Institute of Chemical Physics, Chinese Academy of Sciences, Dalian 116023, China<sup>b</sup> University of Chinese Academy of Sciences, Beijing 100049, China

## ARTICLE INFO

## Article history:

Received 30 September 2014

Received in revised form 13 March 2015

Accepted 22 March 2015

Available online 2 April 2015

## Keywords:

Catalyst

Attrition

Air jet

High temperature

## ABSTRACT

The air jets method proved to be an important tool for assessing attrition propensity of fluidized bed catalyst in the laboratory, but the influence of test temperature and test time has seldom been considered. This paper focuses on the influence of test temperature and test time on the attrition mechanism of methanol to olefins (MTO) catalyst in high velocity air jets. The attrition time was prolonged to 144 h in current study. It has been found that test time should be carefully chosen in order to achieve an equilibrium attrition rate. A short test time is not sufficient to understand the attrition mechanism. Test temperature affects the attrition mechanism significantly. At room temperature the abrasion and fragmentation were found coexisting while at 500 °C the abrasion is dominant. The abrasion of MTO catalyst at 500 °C results in a severe generation of superfine powder that is hard to capture by downstream cyclones, which is in accordance with the findings in industrial MTO unit. Apparently the attrition test at room temperature cannot reflect the generation of superfine powder. Both test time and test temperature should be carefully considered when the air jets method is used in the attrition study in laboratory.

© 2015 The Society of Powder Technology Japan. Published by Elsevier B.V. and The Society of Powder Technology Japan. All rights reserved.

## 1. Introduction

MTO is a process to transform methanol to ethylene and propylene over the SAPO-34 catalyst. After commercialized in 2010, MTO is now becoming one of the most important processes for producing light olefins from alternative resources such as coal and natural gas. MTO reaction is featured by the strong exothermicity and rapid catalyst deactivation [1]. Owing to the advantages of good heat transfer and easy online regeneration, fluidized beds are used as reactor and regenerator in industrial MTO units. However, the smooth operation of fluidized bed reactors is challenged by the attrition of catalyst [1–7] since catalyst particles experience continuous movement and frequent collisions under severe conditions. On one hand, the fines generated by catalyst attrition affect the fluidization and reactor performance due to the change of particle size distribution (PSD) and catalyst surface area. On the other hand, the increasing amount of fines will increase the loading of cyclones, lower the efficiency of solid–gas separation, and eventually lead to considerable catalyst loss. In an industrial unit, the catalyst loss can result in extra operation cost and serious dust emission [8].

In the past decades, intensive studies on catalyst attrition in fluidized beds have been performed in order to understand the attrition mechanism and optimize fluidized bed design and operation [7]. However, the understanding of catalyst attrition mechanism in fluidized bed reactors is a nontrivial task, since the attrition can be a consequence of mechanical stress, thermal stress, chemical stress, and/or any combination of them. It is commonly believed that two different modes of attrition [4,9], i.e. abrasion and fragmentation, can be occurring dependent on catalyst composition, particle structure, particle size, reactor layout and operation conditions of reactor (including gas velocity, temperature, pressure, etc.). If abrasion is dominant, the fines are normally generated from the particle surface because of the lateral cracks and surface wear. In this case, the PSD of mother particles hardly changes, and the fines elutriated from the fluidized bed are too small to be captured. If fragmentation is the leading attrition mode, the mother particles will break down into smaller pieces with similar size. The PSD of mother particles undergoing fragmentation might change significantly, and the fines can be recovered by staged cyclones downstream. In many processes, the abrasion and fragmentation could coexist [9].

The direct measurement of catalyst attrition in an industrial fluidized bed reactor is quite difficult if not impossible. To this end, some methods have been developed to study catalyst attrition in

\* Corresponding author. Tel.: +86 411 84379618; fax: +86 41184379289.

E-mail address: [maoye@dicp.ac.cn](mailto:maoye@dicp.ac.cn) (M. Ye).

**Nomenclature**

AJI	Air Jet Index (%)	$PSD_{rest}$	PSD of the remaining particles in the attrition chamber (-)
$T$	attrition time (h)	$m_{ij}$	mass of the fines collected between $i$ th and $j$ th hour (g)
$m_0$	mass of feed material (g)	$m_{rest}$	mass of the remaining particles in the attrition chamber (g)
$m_{f20}(t)$	mass of fines smaller than 20 $\mu\text{m}$ after a test duration of $t$ (g)	$m_{total}$	mass of all catalyst particles collected after each test (g)
$PSD_{total}$	PSD of all catalyst particles collected after attrition test (-)	$C$	constant
$PSD_{ij}(i < j)$	PSD of the fines collected between $i$ th and $j$ th hour (-)	$n$	constant

laboratory facilities. Forsythe and Hertwig [2] first proposed to evaluate catalyst attrition in laboratory by use of a single air jet. Gwyn [3] improved this method and employed a three-orifice air jet apparatus to investigate particle attrition of fluid catalytic cracking (FCC) catalyst. The three-orifice air jet method is now adopted as the American Society for Testing and Materials (ASTM) standard method (ASTM-D-5757-00) for catalyst attrition assessment [10]. Some researchers such as Cairati et al. [11], Werther and Xi [12], Ghadiri et al. [13], Reppenhagen and Werther [6] applied the air jet method to study attrition of fluidized bed catalyst. In recent years, the jet-cup method has also been employed to study catalyst attrition [14–16]. In the jet-cup method, an air flow with high velocity is jetted tangentially into a cylinder filled with certain quantity of sample catalyst. The jet-cup method has been shown to be much more efficient in terms of test time [14]. But as demonstrated by Cocco et al. [15], there are varying configurations for jet cups. The jet-cup method is yet to be standardized. In fact, Weeks and Dumbill [14] and Zhao et al. [17] used both air jet and jet-cup methods to assess attrition of different type of catalyst, and concluded that the results obtained from these two test methods are comparable in terms of attrition propensity ranking.

In this work, nevertheless, the three-orifice air jet method will be used to study attrition of MTO catalyst. Although the air jet method has been widely used as an important tool to assess catalyst attrition propensity [18–20], it should be aware that the information obtained in the laboratory apparatus cannot quantitatively represent the reality in fluidized bed reactors. Most works on catalyst attrition have been carried out at room temperature [2,3,6,12,13,18–20], where the mechanical stress is the predominant mechanism for particle attrition. Since fluidized bed reactors are normally operated at an elevated temperature, the thermal stress could also contribute to the attrition of catalyst particles. The influence of temperature on particle attrition of silica sand, coal, limestone, and oil shale has been reported by different researchers [21–30]. Lin and Wey [21,22] investigated the attrition of silica sand from room temperature to 900 °C, and found that the higher the temperature, the higher the attrition rate. They noticed that there was a significant deviation between the experimental data at a higher temperature and the prediction results from existing correlations derived at room temperature. Li et al. [23] studied the attrition of silica sand and petroleum coke in a fluidized bed with supersonic nozzles from ambient temperature to 500 °C, and found that the dominant attrition mode is fragmentation at high temperature. The attrition of coal particles was the subject of intensive studies in the past decades [24–26]. It has been generally accepted that for coal particles the fragmentation will be enhanced at an evaluated temperature because the inner pressure of coal particles increases with an increasing temperature [24–26]. Chen et al. [27] investigated the attrition of limestone particles at temperatures from 25 to 580 °C, and found that the attrition is reduced with an increasing temperature. They suggested that the reason is due to the decrease in particle impact velocity and

increase in the threshold particle impact velocity. Hartman et al. [28] reported an experimental study on attrition of lime sorbent in a high-temperature turbulent fluidized bed with quartz sand are presented, in which they proposed a simple mechanistic model to correlate the measured experimental data. Coppola et al. [29] studied the attrition of a limestone during calcium looping cycles for CO<sub>2</sub> capture in a lab-scale fluidized bed at temperatures of 850 °C and 900 °C. It was discovered that a higher calcination temperature can increase the particle attrition rate. Coppola et al. [29] explained this by the sintering of limestone which may bring about hardening of the particle surface. Cui et al. [30] investigated the attrition of oil shale particles in a fluidized bed operating at temperatures from 600 °C to 1000 °C. Their results showed that severer fragmentation occurs at an increasing temperature due to the laminated structure and high ash content of oil shale. To the authors' knowledge, there are only a few reports in the open literature on the attrition of fluidized bed catalyst at an elevated temperature. Johnsen and Grace [31] studied the attrition of sorbents and a catalyst for sorption-enhanced steam methane reforming at a reaction temperature of 550 °C in a gas jet test unit. They found that the co-fluidization of the harder catalyst and the dolomite did not lead to additional attrition of the dolomite. The attrition of iron Fischer–Tropsch catalyst received more attention in recent years [32–34]. Lin et al. [32] report on the attrition properties of a Fischer–Tropsch catalyst in a pilot-scale stirred tank slurry reactor under reaction conditions. They concluded that the catalyst attrition was mainly caused by the fracture. Bukur et al. [33] studied the attrition of a precipitated Fischer–Tropsch catalyst under reaction conditions, and found that the particle size reduction by fracture was moderate, whereas erosion was small. Practically the Fischer–Tropsch reaction in the slurry phase takes place at a relatively low temperature, therefore the mechanical stress due to particles collision and chemical stress arising from phase transformation are considered as two most important mechanisms [32,33]. A recent interesting work by Whitcombe et al. [34] indicated that the mixing of cold fluid catalytic cracking (FCC) catalyst with hot catalyst heated up to 600 °C could lead to the generation of fine particles and metal rich aerosols. They attributed the reason to the thermal shock induced particle fracture. It is also often concerning whether the reduced test time in the laboratory scale studies is sufficient or not in order to understand the attrition mechanism of fluidized bed catalyst. The standard test time defined by ASTM-D-5757-00 is 5 h. Cairati et al. [11] investigated the attrition of different type of catalyst and showed that the test time does affect the test results and should be well beyond the 1 h recommended by Forsythe and Hertwig [2]. In our preliminary study, the test results were also found sensitive to the test time in the air jet method.

This paper will present an experimental study on the attrition of MTO catalyst in a three-orifice air jet apparatus. Particularly, the influence of test temperature and test time on the attrition mechanism of MTO catalyst in high-velocity jets will be addressed and discussed.

## 2. Experimental

### 2.1. Experimental apparatus

As shown in Fig. 1, the experimental apparatus consists of four parts, namely gas-preheating chamber, attrition chamber, particles settling chamber and fines collector. Fines collector is a filter bag made of fiber that can withstand 260 °C and collect fines larger than 0.1 μm. A three-orifice distributor plate of 5 mm thick is placed between the gas-heating chamber and attrition chamber. The orifices are equidistant from each other and 10 mm from the center of the plate. The diameter of orifices is 0.5 mm. Note that the diameter of the orifices is somehow different from that defined in ASTM-D-5757-00, which is  $0.381 \pm 0.005$  mm. The stainless steel gas-preheating chamber and attrition chamber are 462 mm and 733 mm, respectively, in length and 34 mm in inner diameter (the corresponding volumes are  $4.2 \times 10^{-4}$  and  $6.7 \times 10^{-4}$  m<sup>3</sup>, respectively). At the top of the attrition chamber is particles settling chamber with a total length of 620 mm. The inner diameter of the cylindrical section is 110 mm and the upper cone and the lower cone are approximately 120 mm and 235 mm long with two ends converging to 34 mm diameter. In addition, there is a heating device that can heat the device to 700 °C. The experiments in this study were carried out at room temperature and 500 °C with compressed air. Outside the filter bag is at ambient pressure.

### 2.2. Material

Fresh commercial fluidized bed MTO catalyst was screened by 120 and 150 meshes sieves (for size of 125 and 100 μm, respectively) to get a narrow PSD for the sample. The bulk density of

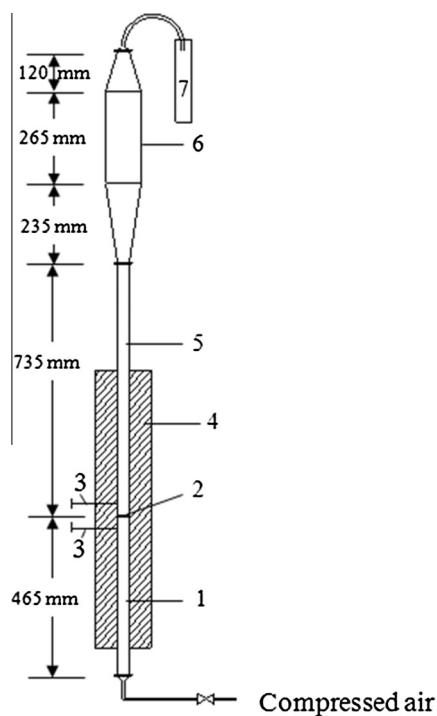

1. Preheating tube
2. Distributor
3. Thermocouple
4. Heating unit
5. Attrition tube
6. Settling chamber
7. Filter bag

Fig. 1. The experimental apparatus for MTO catalyst particles attrition.

the sample is 700 kg/m<sup>3</sup> and the Sauter mean diameter is about 123 μm. Prior to each test, the sample was heated at 600 °C in a muffle furnace for 3 h and cooled down to room temperature in vacuum desiccators.

### 2.3. Attrition measurements

For high temperature experiments, the apparatus was firstly preheated to a pre-set temperature. Then 100 g of MTO catalyst were added into the apparatus from the top of settling chamber with a gas flow of 2 L/min blowing from the bottom to prevent leaking of catalyst particles through the orifices of distributor plate. The attrition chamber was further heated to the desired temperature (500 °C), and the gas flow was then adjusted to the target flow rate. The gas velocity of orifices in this study was 424 m/s. The room temperature experiments followed the same procedure without heating the apparatus.

The attrition time proposed by the standard ASTM-D-5757-00 is 5 h. In this work it is prolonged to 144 h since practically the MTO catalyst has a long life time and can stay in the reactor-regenerator system for years without making-up. Before each test, the PSD of catalyst samples charged into the attrition chamber were measured and recorded. In the test, fine particles were collected by filter bags, and the filter bags were replaced quickly and carefully after a certain interval. The attrition chamber and settling chamber were regularly tapped in order to impel the adhering fines to detach from the inner walls. Actually, the amount of fines adhering to the attrition chamber and the settling chamber is negligible when the test duration is less than 12 h. But it cannot be ignored when the running time is 144 h, which requires careful and frequent tapping on the tube.

### 2.4. Particle size distribution

After each test, the catalyst particles remaining in the attrition chamber (refer to *rest particles* thereafter) were collected. Then, the fines collected in the filter bags and the rest particles in the attrition chamber were weighed and analyzed carefully. A Malvern laser particle size analyzer (Mastersizer 2000) was used to analyze the PSD of samples. The samples were prepared by dispersing the powder with deionized water in an ultrasonic dispersion unit. During the analysis, the light obscuration was monitored to ensure the solid concentration in the dispersant appropriate for PSD measurement. The morphology of catalyst samples was recorded by scanning electron microscope (SEM, Hitachi TM 3000) photographs.

Suppose that the PSD for fines collected between the *i*th and *j*th hour is  $PSD_{ij}(i < j)$ , and the PSD for the rest particles is  $PSD_{rest}$ , it is easy to calculate the PSD for all catalyst particles collected (including fines collected in the filter bags and the rest particles) by

$$PSD_{total} = \frac{\sum_{ij} m_{ij} PSD_{ij} + m_{rest} PSD_{rest}}{m_{total}} \quad (1)$$

$$m_{total} = \sum_{ij} m_{ij} + m_{rest} \quad (2)$$

where  $m_{ij}$  is the mass of fines collected between the *i*th and *j*th hour,  $m_{rest}$  is the mass of the rest particles after each test, and  $m_{total}$  is the mass of all catalyst particles collected after each test.

A material balance calculation was performed for each test, and it was found that less than 1 wt% of the catalyst samples was lost in the experiments. This loss may be due to the elutriation of fines during feeding and discharging.

3. Results and discussion

In ASTM-D-5757-00, the term Air Jet Index (AJI) is defined as the percent of the mass of fines lost from attrition in 5 h to the total mass of catalyst particles initially charged to the apparatus [10]. In order to study the influence of test time, the tests in this work were prolonged to 144 h. Therefore here AJI refers to the percent of the mass of fines lost from attrition for test duration of  $t$  to the total mass of catalyst samples charged to the apparatus at the beginning:

$$AJI = \frac{m_{f20}(t)}{m_0} \times 100 \tag{3}$$

where  $m_{f20}(t)$  is the mass of fines smaller than 20  $\mu\text{m}$  collected by the filter bags after a test duration of  $t$ , and  $m_0$  is the total mass of catalyst samples initially charged to the apparatus.

Tests were performed at both room temperature and 500 °C for different gas velocities, and these results show similar trend. Fig. 2 shows typical AJI measured in these tests. As can be seen, AJI at room temperature varies significantly with test time. A rapid increase of AJI is found in the first hour and after 24 h. In between a relatively small increasing rate can be observed. It is widely anticipated that AJI can be well predicted by the Gwyn formulation [3],

$$AJI = Ct^n \tag{4}$$

Here  $C$  and  $n$  are two constants. From Fig. 3 it is found that at room temperature AJI can be well fitted by Eq. (4) (i.e. a linear function with constant coefficients in the log–log plot) after 24 h. This indicates that the test time of 5 h recommended by ASTM-D-5757-00 is not sufficient for MTO catalyst used in current study. Instead, 24 h should be guaranteed in order to reach the equilibrium attrition rate for MTO catalyst in air jets with high velocity at room temperature. At the elevated temperature of 500 °C, AJI can be fitted reasonably well by Eq. (4) after 2 h, which means the equilibrium attrition rate is readily achieved at an elevated temperature.

AJI was further fitted by Eq. (4) to derive the constants  $C$  and  $n$  for the equilibrium attrition rate. Following the discussion above, AJI from 24 to 144 h was used to fit  $C$  and  $n$  for room temperature, whereas AJI from 2 to 144 h was used for 500 °C. It is interesting to note that the constant  $n$  shows a negligible change when temperature increases to 500 °C. It is 1.233 for room temperature and 1.236 for 500 °C. Neil and Bridgwater [35] studied the Gwyn formulation based on the attrition experiments for different type of particles. They found that the constant  $n$  is independent of the test facilities,

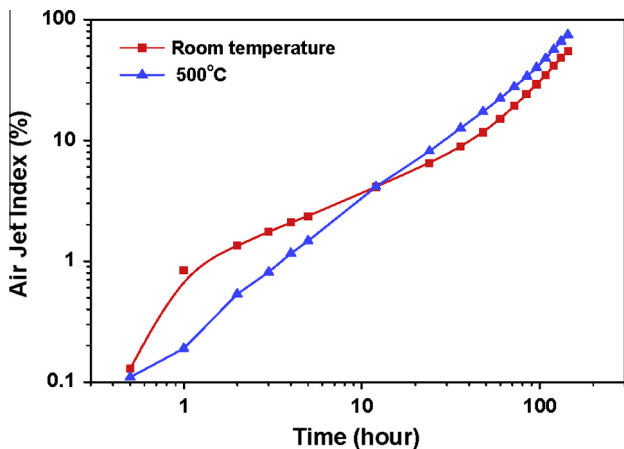

Fig. 2. Air Jet Index (AJI) as a function of test time. AJI is calculated based on the fines collected in the filter bags in the 144-h tests.

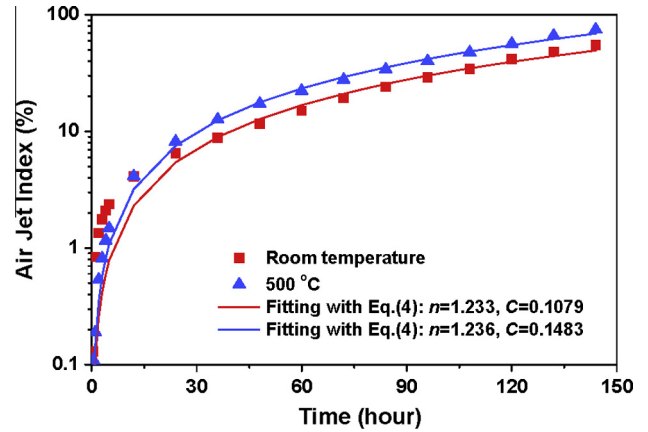

Fig. 3. Air Jet Index (AJI) fitted with the Gwyn formulation given by Eq. (4). AJI is calculated based on the fines collected in the filter bags in the 144-h tests.

and concluded that the constant  $C$  is related to the stress acting on the particles and  $n$  is an indicator of the particle material [35]. In our study, the samples were taken from the same batch of industrial MTO catalyst, and have same material properties. Hence it is not surprised that the constants  $n$  obtained from these two separated tests are consistent. The difference of the constants  $C$ , on the other hand, suggests that the stress acting on the particles is affected by temperature.

In order to understand the attrition mechanism of MTO catalyst in high speed air jets, the evolution of the PSD for fines collected by the filter bags is shown in Figs. 4 and 5. It can be inferred from Fig. 4 that the PSD of fines at room temperature is bimodal with two distinct peaks located at 1–3 and 10–40  $\mu\text{m}$  respectively. It

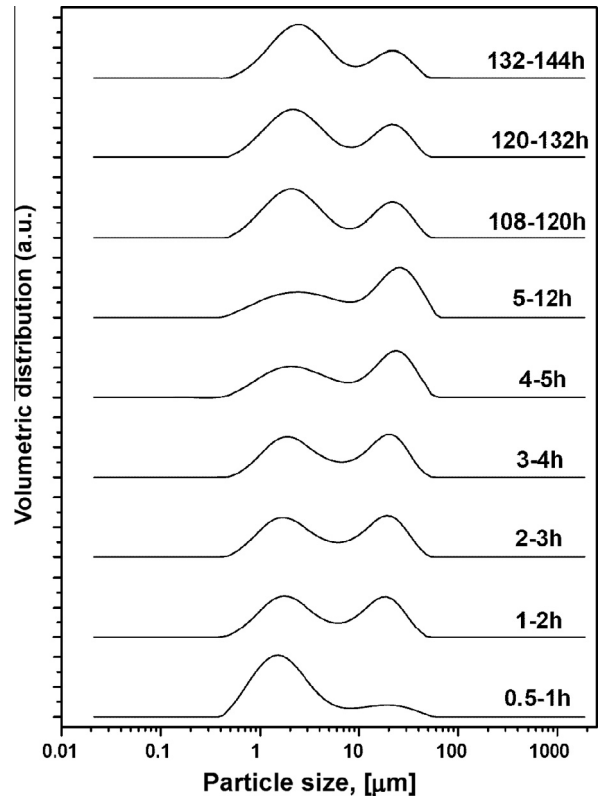

Fig. 4. The evolution of the PSD for fines collected in the filter bags at room temperature.

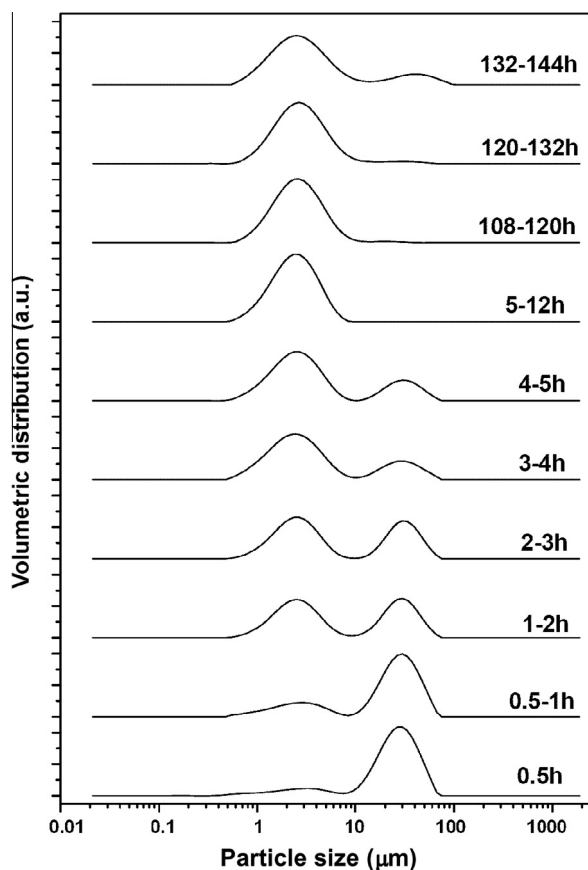

Fig. 5. The evolution of the PSD for fines collected in the filter bags at 500 °C.

is argued that fines with a mean size of 1–3  $\mu\text{m}$  were normally generated by abrasion due to surface wear, while particles with a mean size of 10–40  $\mu\text{m}$  were likely formed by fragmentation due to break down of large solids. The bimodal distribution of fines collected by the filter bags indicates that both the abrasion and fragmentation may exist in high velocity air jets at room temperature. A significant difference, however, is observed in Fig. 5 for the PSD of fines collected in the filter bags at 500 °C. Unlike the bimodal distribution at room temperature, the PSD of fines evolves with test time and three different stages can be identified. In the first stage (test time less than 1 h), a unimodal distribution with the peak at 10–40  $\mu\text{m}$  is found, which indicates that break down of large particles occurred and the fragmentation was the main attrition mode. The second stage lies in between 1 h and 5 h, and is featured by a bimodal distribution with two peaks located at, respectively, 1–3 and 10–40  $\mu\text{m}$ . This is very similar to that at room temperature, and both abrasion and fragmentation are important. In the third stage, the PSD for fines collected in filter bags shifts to a unimodal distribution with mean size of 1–3  $\mu\text{m}$ . This means abrasion became dominant and a large amount of superfine powder was produced.

Different attrition mechanism at room temperature and high temperature can also be evidenced by SEM photographs. Fig. 6(a) is the photograph of fresh MTO catalyst particles. It is visualized that the surfaces of raw particles are rough and a quantity of smaller spherical particles (most are less than 40  $\mu\text{m}$ ) are adhered to the raw particles. This is certainly related to the catalyst manufacturing process. The adhesive force between these small convex particles and mother particles is relative weak, and the linking dots are quite easy to fracture under shear force [7]. A close check with the SEM photograph (Fig. 6(b)) shows that there are some cracks in

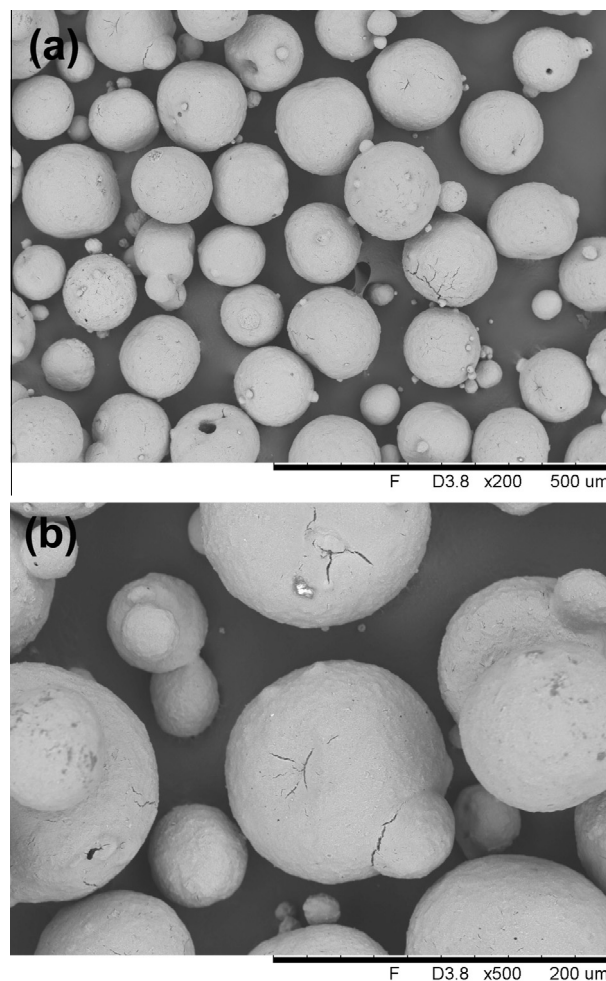

Fig. 6. SEM photographs for fresh MTO catalyst particles.

the junctures, and the convex particles are prone to detach from the mother particles when they collide with each other or the solid walls. The attrition may occur from the juncture firstly regardless of test temperature.

The SEM photographs of fines collected in the filter bags at different time are shown in Fig. 7. As discussed above, the attrition of catalyst starts from the junctures with cracks, and the small convex particles may firstly fracture from the mother particles. In this case, most of fines collected are spherical or near spherical, with a mean particle size of 30  $\mu\text{m}$ . This can be verified by the SEM photographs of fines collected in 0.5 h either at room temperature or at 500 °C. In the photographs, small spherical particles of 30  $\mu\text{m}$  with apparent cross section of fracture can be identified. At room temperature, however, irregular debris possibly caused by fracture of the fragments or chipping from the surface of mother particles is also found. The size of irregular debris is typically in the range of 30  $\mu\text{m}$ . In addition to the irregular debris, a great amount of superfine powder was clearly captured in the SEM photograph at room temperature. The superfine powder may be produced by the surface wear of the irregular debris. Therefore, it can conclude that the fragmentation of small particles adhering to mother particles is responsible for the attrition of MTO catalyst at early stage in high velocity air jets. At room temperature, however, the abrasion due to surface wear of irregular debris also contributes significantly to the production of superfine powder. This results in a higher AJI at room temperature than that at 500 °C at the early stage of attrition test, as illustrated in Fig. 2. As the test time proceeds, as

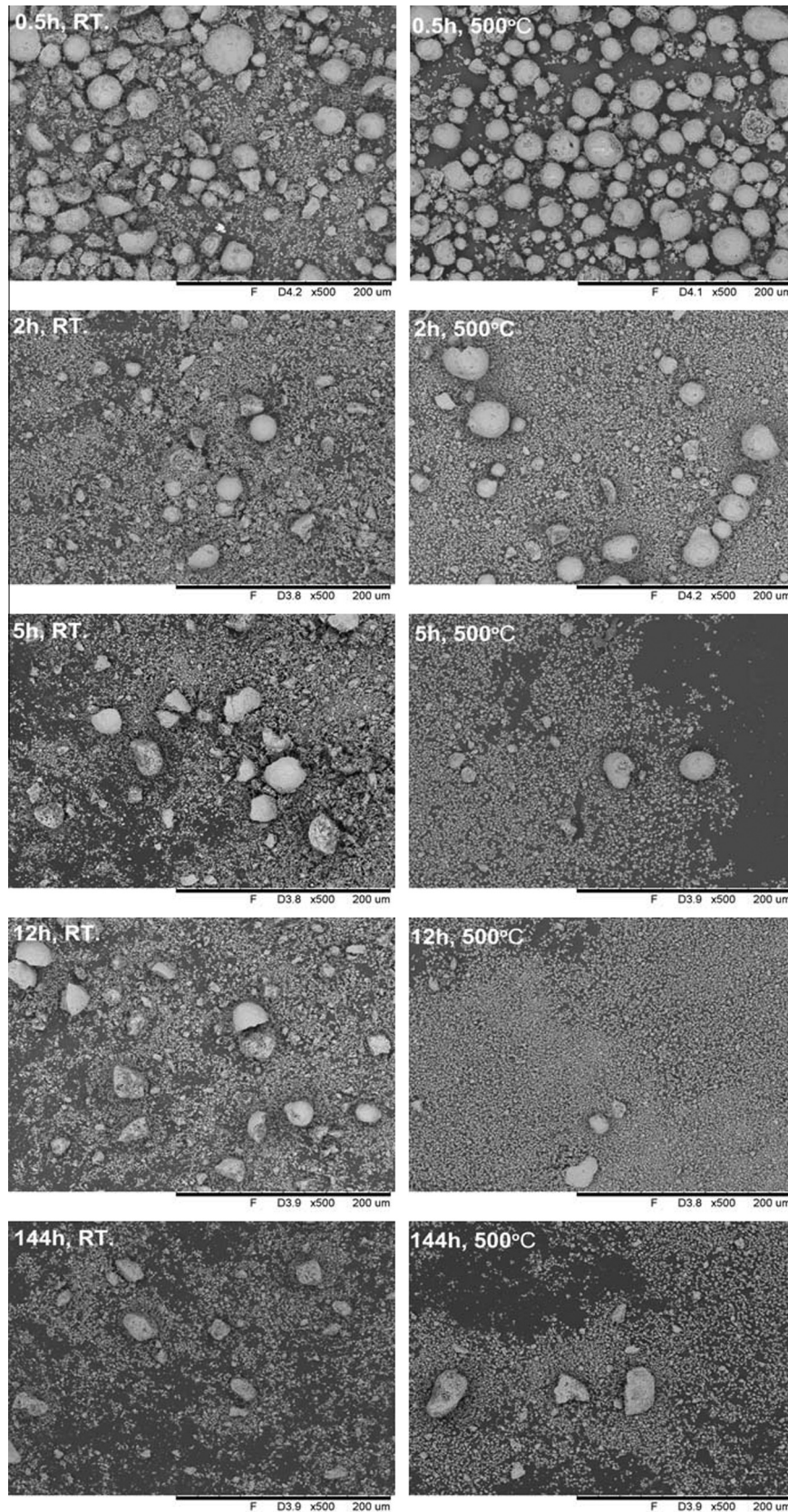

Fig. 7. SEM photographs for fines collected in the filter bags at different test time.

shown in Fig. 7, the fragmentation and abrasion continue to dominate the attrition of MTO catalyst at room temperature. However, the SEM photographs show that at 500 °C the surface wear

becomes the most important attrition mechanism after 5 h in the high velocity air jets, and meantime a large quantity of superfine powder has been generated. In Fig. 8 the SEM photographs

demonstrate the morphology of the rest particles remaining in the attrition chamber after 144 h of test. The smaller adhering particles disappear either at room temperature or at 500 °C after 144 h. A close check with the photographs indicates that at room temperature many concaves caused by the breakage of protrudes on the surface of the rest particles exist. Some fragments not blown out of the attrition chamber can be distinguished. The rest particles have a relatively uniform size and moderately good sphericity. This on the other hand reflects that the abrasion and fragmentation coexist at room temperature. At 500 °C, a quantity of superfine powder adhering to the surface of the rest particles is observed. The rest particles vary significantly in size and shape, and most are non-spherical and much smaller than the fresh MTO catalyst particles. This means abrasion is dominant and a severe reduction of catalyst size can be occurring in the high velocity air jets at 500 °C. The total PSDs for all particles collected after 144 h of tests, as shown in Fig. 9, also support our argument.

Particles' attrition is an extremely complex process, affected by both the hydrodynamic forces in fluidized bed and the mechanical strength of the bed material [36]. According to Werther and Reppenhagen [9], the possible attrition mechanism of catalyst at high temperature might be due to the thermal shock, changes in particle properties, and changes in gas properties. When MTO catalyst particles were heated to a higher temperature, the thermal stress might be induced inside the particles. Typically the MTO catalyst particles consist of SAPO-34 zeolite, matrix and binder. The matrix is mainly clay which can prompt the attrition

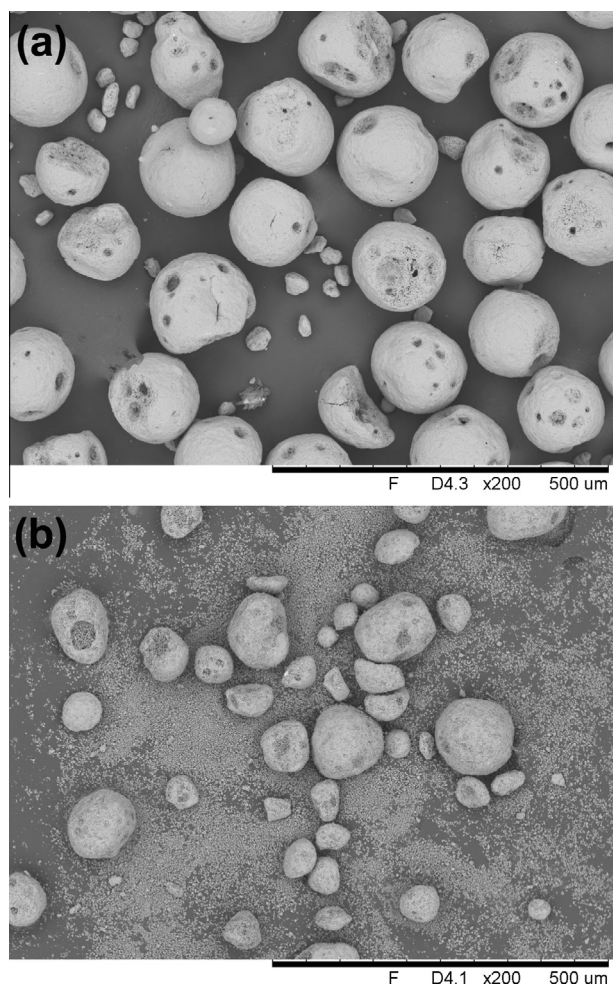

Fig. 8. SEM photographs for the rest particles after 144 h tests: (a) room temperature, (b) 500 °C.

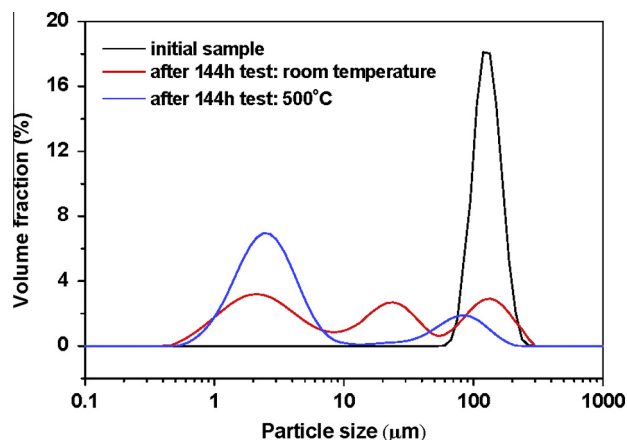

Fig. 9. The total PSDs for all particles collected after 144 h test.

resistance; while the binder is silica, alumina, or silica/alumina solutions, which is used to modify the acidity of the catalyst. Previous studies by Watanabe et al. [37] and Buchholz et al. [38] discovered that SAPO-34 zeolite has high thermal stability, and no change of the crystallinity and microporous structure of framework is expected even after thermal treatment up to 900 °C. However, the material properties of the matrix, including the Young's modulus, brittleness and surface energy, may vary at high temperature [23,27]. It has been found that the sintering temperature and clay content may affect the attrition resistance of porous material [39]. The different attrition mechanisms of MTO catalyst at different temperatures may be due to the change of material properties of the matrix in catalyst particles. At room temperature, the catalyst particles are brittle and easy to break down into similar sizes. At high temperature of 500 °C, the material is softer than that at room temperature, and the particles become more resistant to the mechanical impact. In this case, the chance for fragmentation is significantly reduced and abrasion is the main attrition mode. Actually, as suggested by Werther and Reppenhagen, for any specified type of material there should be an optimal temperature range with respect to the attrition performance [9].

Note that the mean size of the superfine powder produced at 500 °C is in the range of 1–3 μm, and small particles of this size can be elutriated very easily with the gas flow. Practically it is very hard to capture small particles of this size. Specially designed cyclones are desired in order to reduce the cut-off particle size of cyclones and increase the separation efficiency. It also should be stressed that in current study a relatively high gas velocity of 424 m/s was used, and such as high velocity cannot be met in a real MTO fluidized bed reactor. But the attrition mechanism deduced from the experiments of high velocity air jets can reflect the reality to certain extent. In industrial MTO units, a large quantity of superfine powder has been observed in the catalyst slurry from the bottom of the quench tower. Despite that the operation temperature of MTO reactor is also close to 500 °C, our findings in the attrition test at 500 °C agree well with the industrial operation. The generation of superfine powder indeed presents a challenge to industrial MTO fluidized bed reactors, which apparently cannot be discovered by the attrition test at room temperature.

#### 4. Conclusions

Fluidized bed reactors are normally operated at an elevated temperature. The air jets method has been proved to be an important tool for assessing attrition propensity of fluidized bed catalyst in the laboratory, but the influence of test temperature and test time has seldom been taken into account. In addition to the

mechanical stress, the thermal stress could also contribute to the attrition of catalyst particles in fluidized bed reactors. In this paper an experimental study on the attrition of MTO catalyst by use of a three-orifice air jet apparatus has been performed, with focus on the influence of test temperature and test time on the attrition mechanism of MTO catalyst in high-velocity air jets.

The attrition time was prolonged to 144 h in current study. It has been found that at room temperature at least test time of 24 h is desired in order to achieve an equilibrium attrition rate. At an elevated temperature of 500 °C, the test time can be reduced to 2 h. A short test time might not be sufficient to understand the attrition mechanism. Test temperature has a significant influence on the attrition mechanism. At room temperature, the abrasion and surface fragmentation could coexist, leading to bimodal distribution for the PSD of fines collected in the filter bags. At 500 °C the abrasion becomes dominant in the high velocity jets, which results in a severe reduction of catalyst size and generation of a large quantity of superfine powder that is hard to capture by downstream cyclones, which is in accordance with the findings in the catalyst slurry from the bottom of the quench tower. Apparently the attrition test at room temperature cannot reflect the generation of superfine powder. Both test time and test temperature therefore should be carefully considered when the air jets method is used in the attrition study in laboratory.

### Acknowledgements

This work is supported by the National Natural Science Foundation of China (Grant No. 91334205), the Strategic Priority Research Program of the Chinese Academy of Sciences (Grant No. XDA07080302), and the National High-tech R&D Program of China (863 Program) (Grant No. 2012AA051001).

### References

- [1] M. Kim, H.-J. Chae, T.-W. Kim, K.-E. Jeong, C.-U. Kim, S.-Y. Jeong, Attrition resistance and catalytic performance of spray-dried SAPO-34 catalyst for MTO process: effect of catalyst phase and acidic solution, *J. Ind. Eng. Chem.* 17 (2011) 621–627.
- [2] W.L. Forsythe, W.R. Hertwig, Attrition characteristics of fluid cracking catalysts-laboratory studies, *Ind. Eng. Chem.* (1949) 1200–1206.
- [3] J.E. Gwyn, On the particle size distribution function and the attrition of cracking catalysts, *AIChE J.* 15 (1969) 35–39.
- [4] J. Wei, W. Lee, F.J. Krambeck, Catalyst attrition and deactivation in fluid catalytic cracking system, *Chem. Eng. Sci.* 32 (1977) 1211–1218.
- [5] Y.C. Ray, T.S. Jiang, C.Y. Wen, Particle attrition phenomena in a fluidized bed, *Powder Technol.* 49 (1987) 193–206.
- [6] J. Werther, J. Reppenhagen, Catalyst attrition in fluidized-bed systems, *AIChE J.* 45 (1999) 2001–2010.
- [7] R. Boerefijn, N.J. Guddé, M. Ghadiri, A review of attrition of fluid cracking catalyst particles, *Adv. Powder Technol.* 11 (2000) 145–174.
- [8] C.R. Bemrose, J. Bridgwater, A review of attrition and attrition test methods, *Powder Technol.* 49 (1987) 97–126.
- [9] J. Werther, J. Reppenhagen, Attrition in fluidized beds and pneumatic conveying lines, in: W.-C. Yang (Ed.), *Handbook of Fluidization and Fluid-particle Systems*, Marcel Dekker, New York, 2003, pp. 201–237.
- [10] ASTM-D-5757-00, Standard Test Method for Determination of Attrition and Abrasion of Powdered Catalysts by Air Jets, ASTM, 2006.
- [11] L. Cairati, L. Difiore, P. Forzatti, I. Pasquon, F. Trifiro, Oxidation of methanol in a fluidized bed. 1. Catalyst attrition resistance and process variable study, *Ind. Eng. Chem. Process Des. Dev.* 19 (1980) 561–565.
- [12] J. Werther, W. Xi, Jet attrition of catalyst particles in gas fluidized beds, *Powder Technol.* 76 (1993) 39–46.
- [13] M. Ghadiri, J.A.S. Cleaver, V.G. Tuponogov, J. Werther, Attrition of FCC powder in the jetting region of a fluidized bed, *Powder Technol.* 80 (1994) 175–178.
- [14] S.A. Weeks, P. Dumbill, Method speeds FCC catalyst attrition resistance determinations, *Oil Gas J.* 88 (1990) 38–40.
- [15] R. Cocco, Y. Arrington, R. Hays, J. Findlay, S.B.R. Karri, T.M. Knowlton, Jet cup attrition testing, *Powder Technol.* 200 (2010) 224–233.
- [16] R. Cocco, S.B. Reddy Karri, Y. Arrington, R. Hays, J. Findlay, T. Knowlton, Particle attrition measurements using a jet cup, in: *The 13th International Conference on Fluidization*, Gyeong-ju, Korea, 2010.
- [17] R. Zhao, J.G. Goodwin, K. Jothimurugesan, J.J. Spivey, S.K. Gangwal, Comparison of attrition test methods: ASTM standard fluidized bed vs jet cup, *Ind. Eng. Chem. Res.* 39 (2000) 1155–1158.
- [18] M. Filla, L. Massimilla, S. Vaccaro, Gas jets in fluidized beds – The influence of particle size, shape and density on gas and solids entrainment, *Int. J. Multiph. Flow* 9 (1983) 259–267.
- [19] S.Y. Wu, J. Baeyens, C.Y. Chu, Effect of the grid-velocity on attrition in gas fluidized beds, *Can. J. Chem. Eng.* 77 (1999) 738–744.
- [20] G. Xiao, J.R. Grace, C.J. Lim, Attrition characteristics and mechanisms for limestone particles in an air-jet apparatus, *Powder Technol.* 207 (2011) 183–191.
- [21] C.L. Lin, M.Y. Wey, Effects of high temperature and combustion on fluidized material attrition in a fluidized bed, *Korean J. Chem. Eng.* 20 (2003) 1123–1130.
- [22] C.L. Lin, M.Y. Wey, Influence of hydrodynamic parameters on particle attrition during fluidization at high temperature, *Korean J. Chem. Eng.* 22 (2005) 154–160.
- [23] F. Li, C. Briens, F. Berruti, J. McMillan, Particle attrition with supersonic nozzles in a fluidized bed at high temperature, *Powder Technol.* 228 (2012) 385–394.
- [24] R. Chirone, L. Massimilla, The application of Weibull theory to primary fragmentation of a coal during devolatilization, *Powder Technol.* 57 (1989) 197–212.
- [25] P. Dacombe, M. Pourkashanian, A. Williams, L. Yap, Combustion-induced fragmentation behavior of isolated coal particles, *Fuel* 78 (1999) 1847–1857.
- [26] S.H. Lee, S.D. Kim, D.H. Lee, Particle size reduction of anthracite coals during devolatilization in a thermobalance reactor, *Fuel* 81 (2002) 1633–1639.
- [27] Z. Chen, C. Jim Lim, J.R. Grace, Study of limestone particle impact attrition, *Chem. Eng. Sci.* 62 (2007) 867–877.
- [28] M. Hartman, K. Svoboda, M. Pohořelý, M. Šyc, M. Jeremiáš, Attrition of dolomitic lime in a fluidized-bed reactor at high temperatures, *Chem. Pap.* 67 (2013) 164–172.
- [29] A. Coppola, F. Montagnaro, P. Salatino, F. Scala, Attrition of limestone during CO<sub>2</sub> capture in a fluidized bed calcium loop process, *Combust. Sci. Technol.* 184 (2012) 929–941.
- [30] Z. Cui, X. Han, X. Jiang, J. Liu, Experiment and neural network model of primary fragmentation of oil shale in fluidized bed, *Oil Shale* 26 (2009) 114–124.
- [31] K. Johnsen, J.R. Grace, High-temperature attrition of sorbents and a catalyst for sorption-enhanced steam methane reforming in a fluidized bed environment, *Powder Technol.* 173 (2007) 200–202.
- [32] T.-J. Lin, X. Meng, L. Shi, Attrition studies of an Iron Fischer–Tropsch catalyst used in a pilot-scale stirred tank slurry reactor, *Ind. Eng. Chem. Res.* 51 (2012) 13123–13131.
- [33] D.B. Bukur, W.P. Ma, V. Carreto-Vazquez, Attrition studies with precipitated iron Fischer–Tropsch catalysts under reaction conditions, *Topics Catal.* 32 (2005) 135–142.
- [34] J.M. Whitcombe, I.E. Agranovski, R.D. Braddock, Attrition due to mixing of hot and cold FCC catalyst particles, *Powder Technol.* 137 (2003) 120–130.
- [35] A.U. Neil, J. Bridgwater, Towards a parameter characterising attrition, *Powder Technol.* 106 (1999) 37–44.
- [36] M. Hartman, K. Svoboda, M. Pohořelý, M. Šyc, Attrition of a mineral catalyst in a fluidized-bed gasification reactor, *Chem. Listy* 106 (2012) 844–846.
- [37] Y. Watanabe, A. Koiwai, H. Takeuchi, S.A. Hyodo, S. Noda, Multinuclear NMR studies on the thermal stability of SAPO-34, *J. Catal.* 143 (1993) 430–436.
- [38] A. Buchholz, W. Wang, M. Xu, A. Arnold, M. Hunger, Thermal stability and dehydroxylation of Bronsted acid sites in silicoaluminophosphates H-SAPO-11, H-SAPO-81 H-SAPO-31, and H-SAPO-34 investigated by multi-nuclear solid-state NMR spectroscopy, *Microporous Mesoporous Mater.* 56 (2002) 267–278.
- [39] N. van Garderen, F.J. Clemens, M. Mezzomo, C.P. Bergmann, T. Graule, Investigation of clay content and sintering temperature on attrition resistance of highly porous diatomite based material, *Appl. Clay Sci.* 52 (2011) 115–121.